

Electric roll-up screens ER1 (Variant ER1/2 shown)

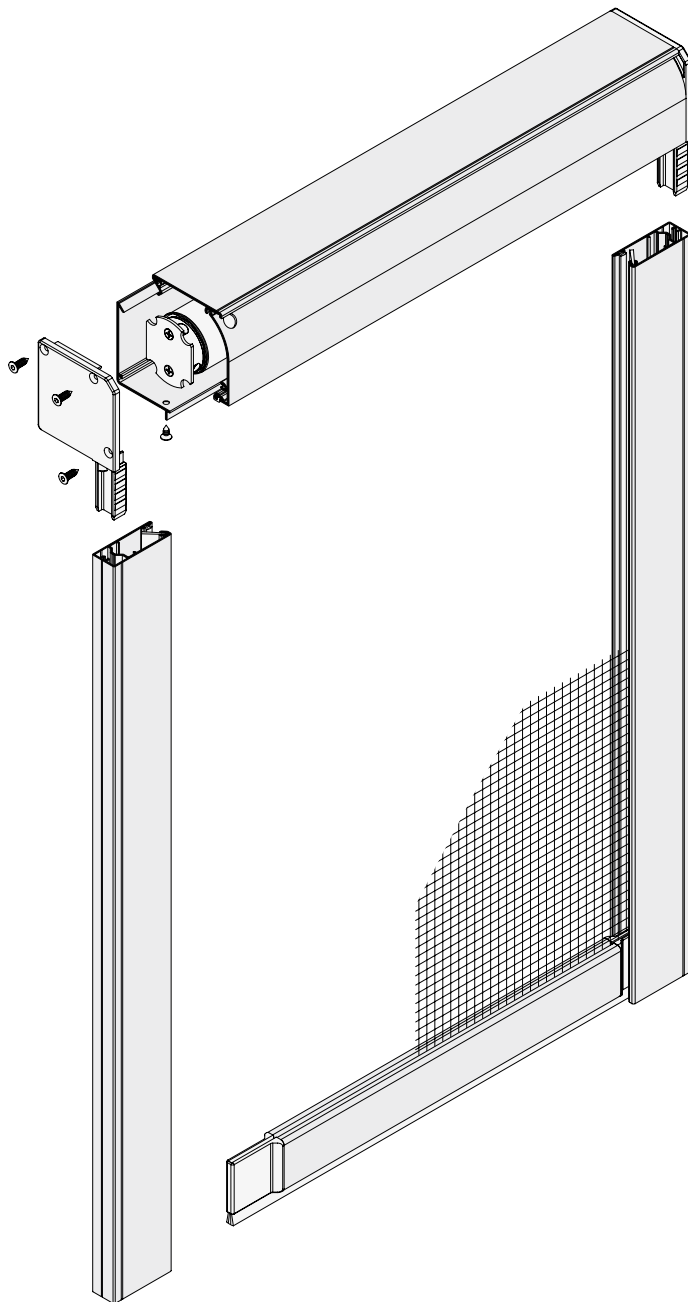

HINGED SERVICE COVER

The cover of the screen roll case can be easily folded out even in its installed position.

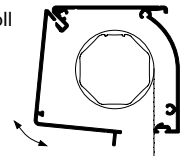

When the roller blind screen case is installed in a recess, a split cover is used.

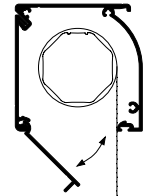

With both cover types, the mesh roll can be removed when the case is installed. This allows easy maintenance of the mesh and motor.

HIGH-SPEED MOTOR WITH SAFETY FEATURES

The high-speed motor (70 rpm) is available with and without radio control. The motor is equipped with a safety feature for hitting an obstacle in the downward movement. That means when the mesh bar hits an obstacle the motor stops, reverses a bit (override function) and stops again. The motor excels by its silent operation and soft deceleration.

SIDE GUIDING RAILS

The mesh is guided by the brush pile system that has been tried and tested for many years now. With 20 mm the guide channel is still slim and has a separate installation pocket.

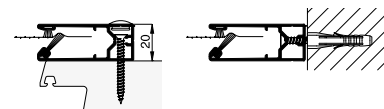

MECHANICAL TYPE

The electric roll-up screen ER1 can also be equipped with a spring-supported tube.

This allows using the ER1 screen both for windows and doors either operated electrically (tube motor) or mechanically (spring-supported tube). Both versions can be retrofitted.

Therefore, this universal roller blind screen system is easy to plan.

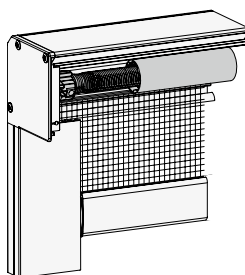

EASY INSTALLATION

The mesh roll case is self-supporting on the guiding rails up to 1500 mm width. For large units or separate case installation a mounting plate is provided where the case is hooked in and can be screwed (without drilling).

