

## Single operation

SCHEMATIC CIRCUIT DIAGRAM

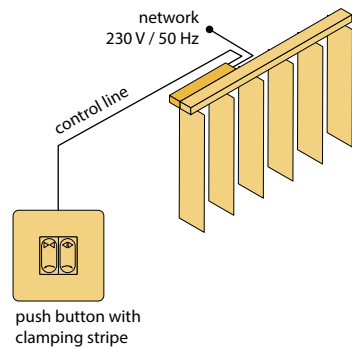

WIRING DIAGRAM

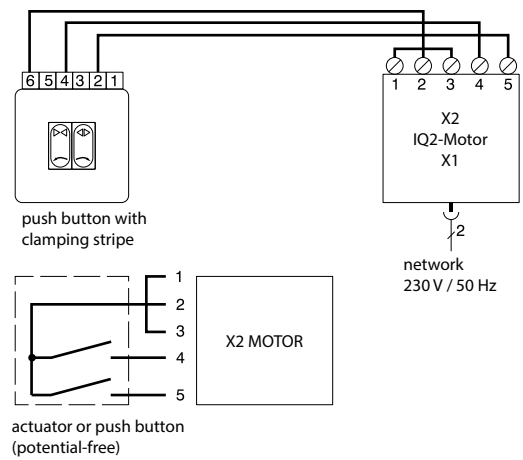

## Group operation

SCHEMATIC CIRCUIT DIAGRAM

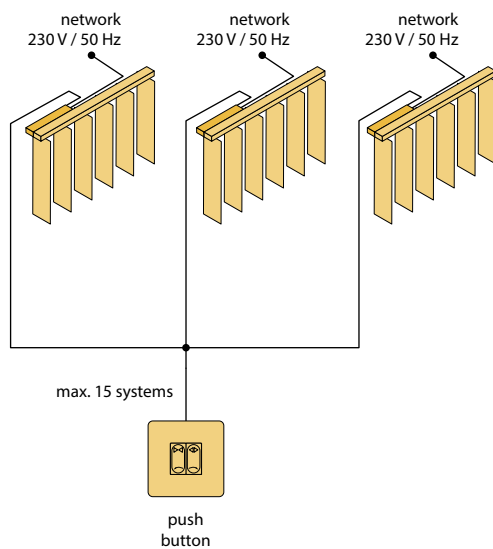

WIRING DIAGRAM

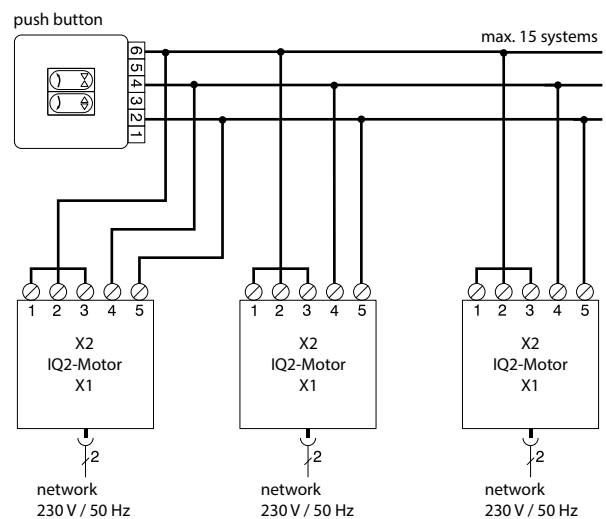

⚠️ Clamp X2/1 must **not** be connected in the case of group operation!

# Circuit diagrams IQ2 motor

Vertical blinds

## Radio control

### SCHEMATIC CIRCUIT DIAGRAM

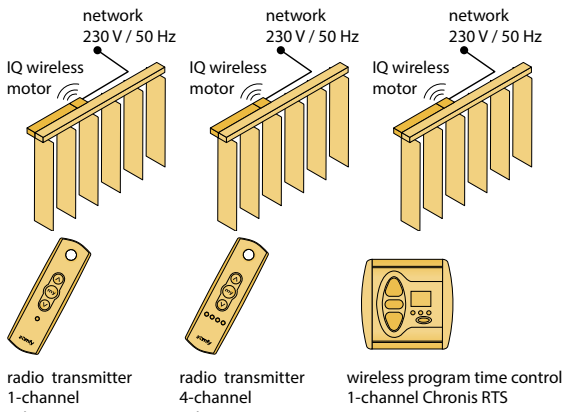

Other radio transmitters on request

### WIRING DIAGRAM

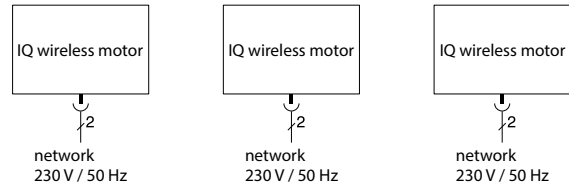

## Single operation with 230 V push button module

### SCHEMATIC CIRCUIT DIAGRAM

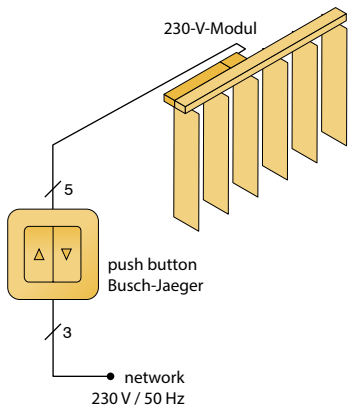

### WIRING DIAGRAM

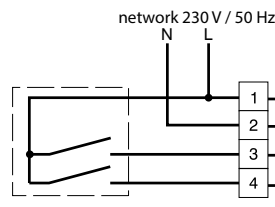
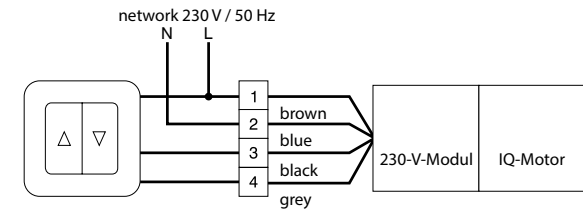

push button or venetian blind-actuator 230 V

## Group operation with 230 V push button module

### SCHEMATIC CIRCUIT DIAGRAM

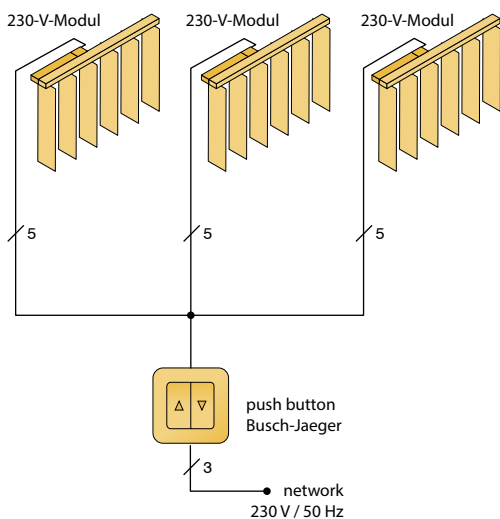

### WIRING DIAGRAM

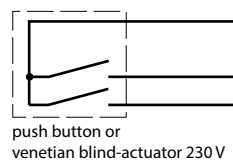
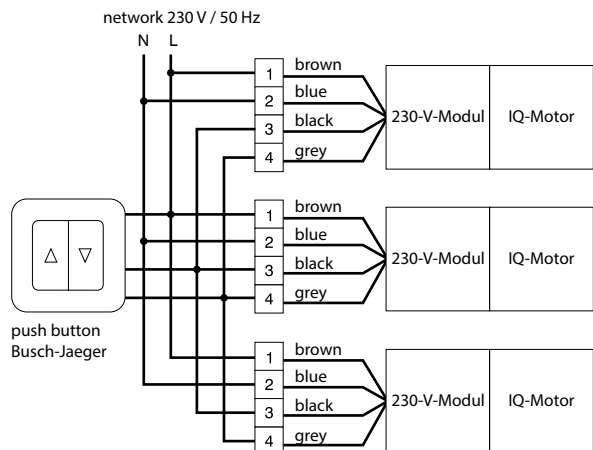

## Ceiling operation with IQ2 motor

SCHEMATIC CIRCUIT DIAGRAM

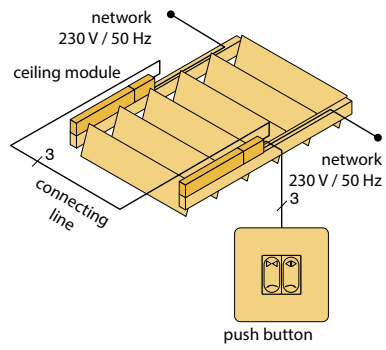

WIRING DIAGRAM

